

DEFENDER CAVITY FIT RESTRICTOR

For Child Safety

DEFENDER CAVITY FIT RESTRICTOR

THE ULTIMATE
SOLUTION TO CHILD
SAFETY

- Tested to BS 6375 Part 2 to withstand a force of 600N when opened at the restricted position
- Austenitic 304* stainless steel for enhanced corrosion resistance
- Compatible with all Securistyle domestic hinges including the Defender Egress Easy Clean
- 10 year guarantee (details available upon request)



▲ CHILD RESISTANT
mechanism limits maximum
opening

▼ CAVITY LOCATOR PIN
for each standard cavity height



* Austenitic (was 304) stainless steel to BS EN ISO 10088/2 Grade 1.4301 for enhanced corrosion resistance.



DEFENDER CAVITY FIT RESTRICTOR

For Child Safety

PRODUCT SPECIFICATION

- Easy to fit with no routing required
- Compatible with standard countersunk fixings
- Can be used on windows without reinforcement
- Available in 13mm, 16mm and 17mm cavity heights
- Left and right hand product available
- Compatible with Securistyle 16mm stack height commercial hinges: Sterling & Storm

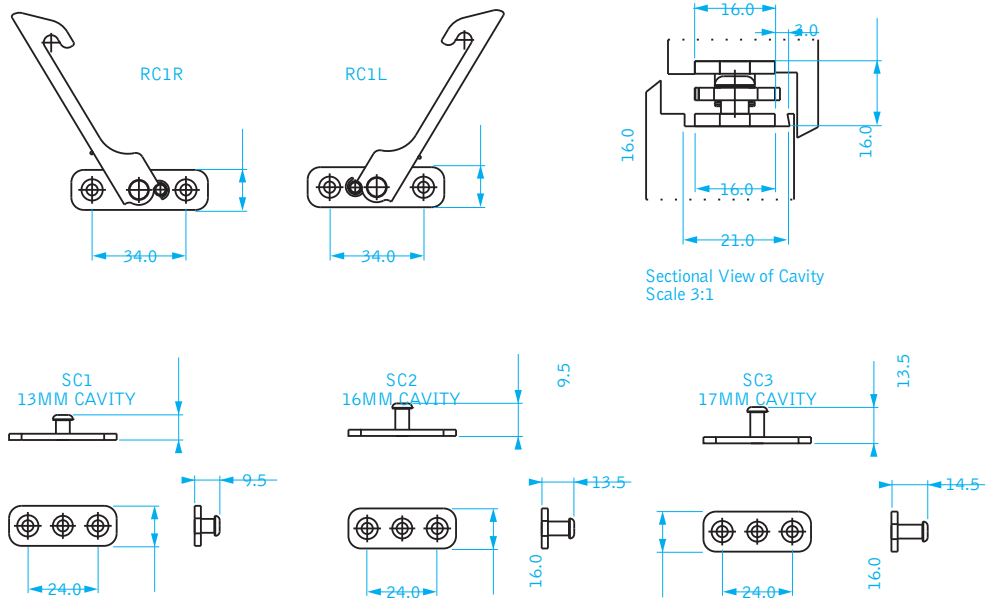

DEFENDER CAVITY FIT RESTRICTOR

Part Codes	Description	Cavity Size	Boxed Qty.
SC1	13mm Locator Pin	13mm	25
SC2	16mm Locator Pin	16mm	25
SC3	17mm Locator Pin	17mm	25
RC1L	Cavity Restrictor Left Hand		25
RC1R	Cavity Restrictor Right Hand		25



INVESTOR IN PEOPLE



Due to our policy of continual improvement we reserve the right to alter specifications without notice. It is the responsibility of the window manufacturer to ensure that the finished window meets the required performance and safety specification.

All transactions are subject to our standard conditions of supply, which are available on request.